

1 2 3 4 5 6

A

A

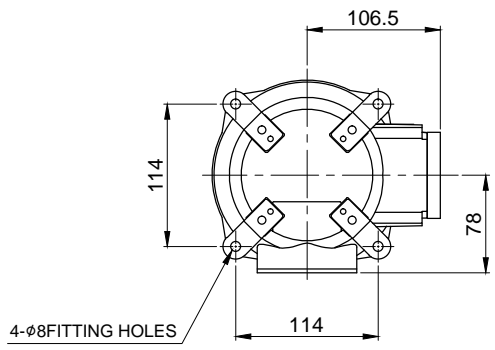
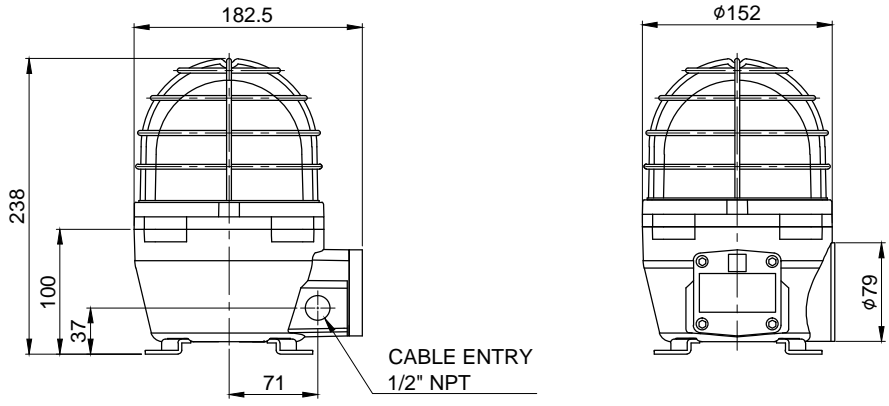

MARK	DATE	REVISION	REVISER	APP. BY
①				
②				
③				

MODEL NO		SNE		
MATERIAL		HOUSING-AL		
		LENS-TEMPERED GLASS		
		PROTECTION CAGE-SS316L		
		REFLECTOR-PC		
COLOR OF LENS		RED( ), AMBER( ), GREEN( ), BLUE( )		
REV. PER MIN.		120 ~ 140		
USE VOLT.	BULB	CURRENT	15W	MAX. 1.155A
				MAX. 0.766A
				MAX. 0.204A
				MAX. 0.102A
PROTECTION GRADE		WATER & DUST PROOF IP66		
CABLE ENTRY		1/2" NPT		
COLOR OF HOUSING		MUNSELL NO. 7.5BG 7/2		
ACTION		BLUB REVOLVING WARNING LIGHT		

B

B

C

C

D

D

FOR LINEAR DIMENSIONS	ISO2768-1 : CLASS OF TOLERANCE					SURFACE FINISH
	f	m	Ⓢ	v		
0.5-3	±0.05	±0.1	±0.2	-		
3-6			±0.3	±0.5		
6-30	±0.1	±0.2	±0.5	±1		
30-120	±0.15	±0.3	±0.8	±1.5		
120-400	±0.2	±0.5	±1.2	±2.5		
400-1000	±0.3	±0.8	±2	±4		
FOR ANGULAR DIMENSIONS	0-10	±1°	±1°30'	±3°		
	10-50	±0°30'	±1°	±2°		
	50-120	±0°20'	±0°30'	±1°		
	120-400	±0°10'	±0°13'	±0°30'		

Nr.	DWG. NO.	TITLE/ NAME		MAT'L	1	
DSND BY	CHKD BY	CHKD BY	APRV BY	VIEW	DATE	REFERENCE
S.H.KIM	J.H.PARK		J.K.HAN	3	2016.08.30	
TITLE			MODEL			
SNE OUTLINE DRAWING			SNE			
			DWG. NO.		SNE_OUT	
SCALE		SIZE	REV	SHEET		
N/S		A4	00	1/1		

1 2 3 4 5 6

A4(297X210)