

MARK	DATE	REVISION	REVISER	APP .BY
△				
△				
△				

MODEL No.	SLP5130-AL
MATERIAL	HEAD & BODY - DIE CAST AL BOLT,NUT & ETC. - SUS304 , ROLLER - POM
CONATCT	2CKT-DB, 1A1B, 250VAC 6A
PROTECTION GRADE	EXPLOSION PROOF - Exd II c T6 WATER & DUST PROOF - IP67
CABLE ENTRY	STANDARD - NPT 1/2 OPTION - NPT 3/4
COLOR	MAKER STANDARD
INSULATION RESISTANCE	100MΩ MIN. at 500V DC
CERTIFICATE	KIMM, KOSHA

Operating Characteristics

OF max.g	1,300
RF min.g	210
PT	15° ± 5°
MD max.	5°
TT min	70°

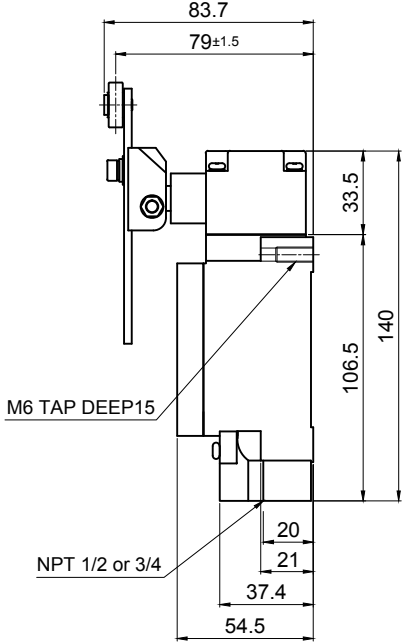
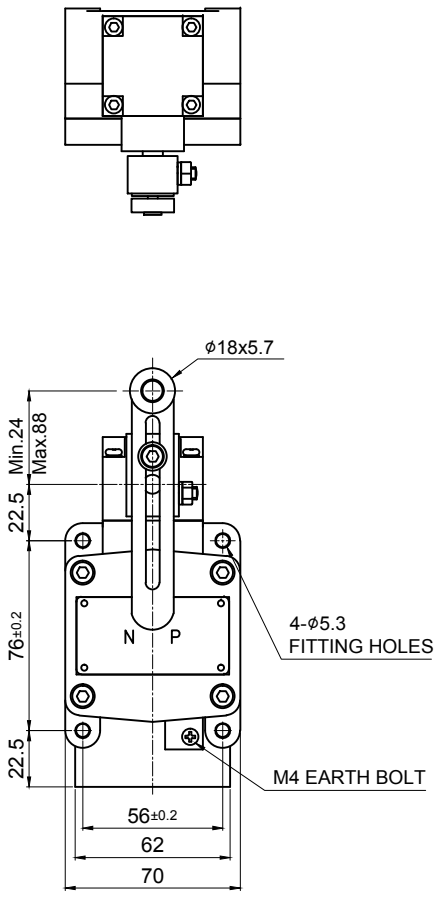

	ISO2768-1 : CLASS OF TOLERANCE				SURFACE FINISH
	f	m	c	v	
FOR LINEAR DIMENSIONS	0.5~3	±0.05	±0.1	±0.2	-
	3~6			±0.3	±0.5
	6~30	±0.1	±0.2	±0.5	±1
	30~120	±0.15	±0.3	±0.8	±1.5
	120~400	±0.2	±0.5	±1.2	±2.5
	400~1000	±0.3	±0.8	±2	±4
FOR ANGULAR DIMENSIONS	0~10	±1°	±1°30'	±3°	
	10~50	±0°30'	±1°	±2°	
	50~120	±0°20'	±0°30'	±1°	
	120~400	±0°10'	±0°13'	±0°30'	

Nr.	DWG. NO.	TITLE/ NAME	MAT'L	QTY	REFERENCE
DSND BY	CHKD BY	CHKD BY	MODEL	VIEW	DATE
S.H.KIM	J.H.PARK		J.K.HAN	3	2012.01.27
TITLE			MODEL		
SLP5130-AL OUTLINE DRAWING			SLP5130-AL		
			DWG. NO.		
			SLP5130-AL-OUT		
SCALE	SIZE	REV	SHEET		
N/S	A4	00	1/1		