

# Weight Type

## 중추형 리미트 스위치

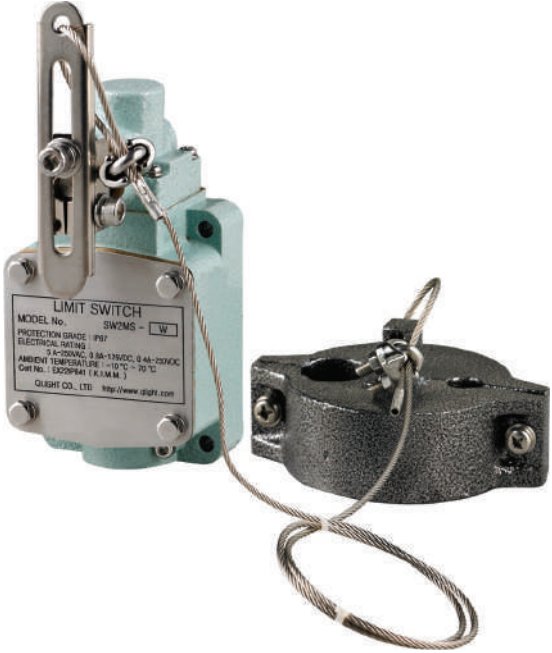

### ■ 특징(Features)

- 기계적 강도가 높아 Actuator에 가해지는 불안정한 움직임을 유연하게 흡수하여 안정된 동작을 수행
- 당사 독자 구조인 2중 스프링 복귀 시스템을 채택, 장기간 스위치 ON상태를 유지한 후에도 안정된 동작 특성을 발휘
- 외부에 사용된 볼트 및 너트 종류는 스텐 재질로 내부식성이 우수
- 로프용 추의 하중이 해제되었을 때 센서를 동작/복귀 시키는 형으로 BOOM의 선단과 같이 스위치의 수평각도가 변화하는 상태에서 우수한 동작특성 발휘
- 선박갑판기계, 항만하역설비, 옥외건설장비, 화학공장, 옥외플랜트 설비용으로 적합
- 보호구조 : SW2MS(IP67), 6560S, 8560(IP56)
- 내한형 (-40°C~+40°C)과 내열형 (+50°C~+120°C)은 주문 사양으로 제작 공급

- This item has a mechanical strength to absorb an unstable motion to the Actuator smoothly, so it performs a stable motion well.
- Our independent system, Strong returning system with double springs was taken for this item, so it maintains its stable motion after switching on for a long term.
- Stainless(STS) bolts and nuts used outside have a strong anti-corrosion.
- When releasing the pendulum weight, this item will make a sensor working.
- So it specially work well when changing its switch horizontal angle like BOOM fleet.
- This item is suitable for ship deck machinery, dock cargo handling equipment, outdoor building equipment, chemical factory, outdoor plant facilities.
- Protection Class: SW2MS(IP67), 6560S, 8560(IP56)
- We will offer custom-made item for Cold-proof type(-40°C to +40°C) and Heat-resisting type(+50°C to +120°C)

### ■ 회로 구성 및 정격(Circuit & Electrical Rating)

	<ul style="list-style-type: none"> <li>• 10A - 125V    • 5A - 250V</li> <li>• 0.8A - 125VDC    • 0.4A - 125VDC</li> </ul>
	<ul style="list-style-type: none"> <li>※ 상세한 부하별 정격은 Page 8을 참고하십시오.</li> <li>※ Refer to Page 8 for detailed electrical rating by load</li> </ul>

### ■ 사양(Specifications)

보호구조 (Protection Grade)		IP56/ 67
기계적 수명 (Mechanical Life)		Over 0.5 million operations
전기적 수명 (Electrical Life)		Over 0.1 million operations
허용 동작 빈도 (Allowable Operating Cycle)	기계적 (Mechanical)	120 Operations per minute max.
	전기적 (Electrical)	30 Operations per minute max.
절연저항 (Insulation Resistance)		100MΩ min. at 500V DC
접촉저항 (Initial Resistance)		50MΩ max.
내전압 (Dielectric Strength)	비연속단자간 (Between Non-continuous Terminal)	1,000V AC, 50 to 60Hz for 1 minute
	각단자와 비충전금속부간 (Between Each Terminal and Non-conducting Metal Part)	2,000V AC, 50 to 60Hz for 1 minute
내충격 (Shock Resistance)	내구 (Destruction)	Approx. 1,000m/s <sup>2</sup> (100G)
	오동작 (Malfunction)	Approx. 250m/s <sup>2</sup> (25G)
진동 (Vibration Resistance)		10 to 55Hz 1.5mm double amplitude(복진폭)
사용주위 온도범위 (Allowable Operating Temperature Range)		-10°C to +55°C
사용주위 습도범위 (Ambient Humidity Range)		45 ~ 85% RH

# Weight Type

## 중추용 리미트 스위치

### SW2MS-W

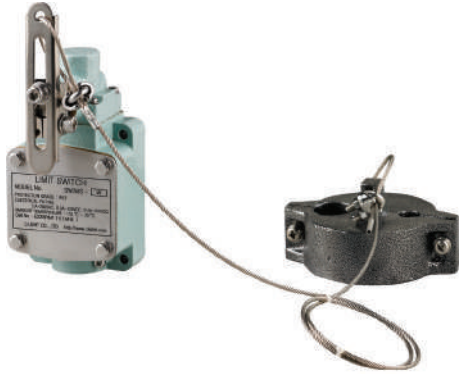

#### • 동작특성 Operating Characteristics

OF max.g	1,800
RF min.g	1,400
PT	25°
MD max	15°
TT min	50°

#### • 중량 Weight

SW2MS-W	Abt. 3.29kg
---------	-------------

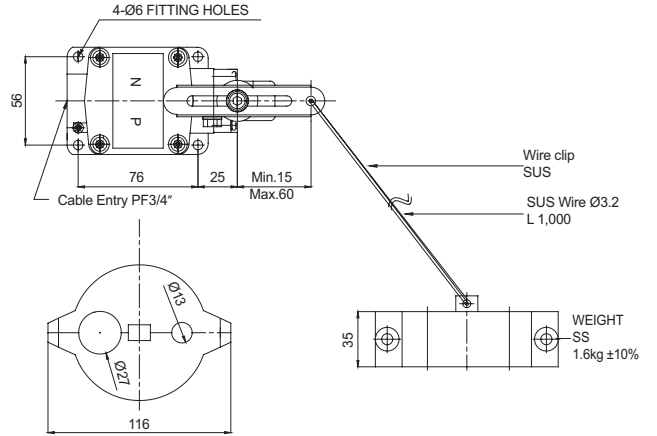

### SH6560S-W



#### • 동작특성 Operating Characteristics

OF max.g	1,800
RF min.g	1,400
PT	25°
MD max	15°
TT min	50°

#### • 중량 Weight

SH6560S-W	Abt. 2.80kg
-----------	-------------

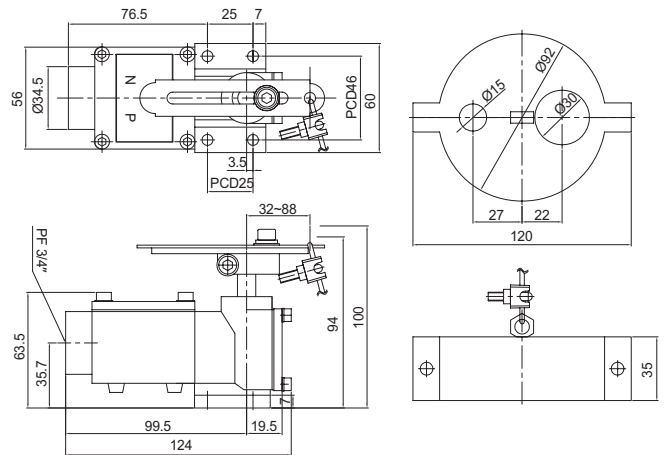

### SH8560-W/ SH8560S-W



#### • 동작특성 Operating Characteristics

OF max.g	2,300
RF min.g	1,800
PT	25°
MD max	15°
TT min	50°

#### • 중량 Weight

SH8560-W	Abt. 4.30kg
SH8560S-W	Abt. 6.70kg

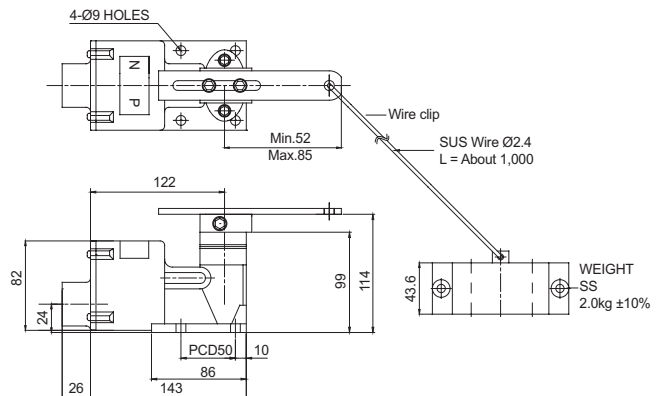

※ 주.

1. 상기 치수중 지정하지 않은 부분의 치수 공차는 ±0.4mm 입니다.
2. 방수 또는 옥외용으로 사용하실 때는 방수용 콘넥터 또는 CABLE GLAND를 사용하시기 바랍니다.
3. 방수용 콘넥터 또는 CABLE GLAND를 사용하지 않는 상태로 옥외에 임시 설치하실 경우에는 방수에 유의하시기 바랍니다.
4. 케이블 인입구는 PF3/4"의 표준 치수로 제작합니다.

※ Remarks & Caution

1. The size allowance not indicated on the above is ±0.4mm.
2. In case the product is installed outdoor or for water-proof usage, use water-proof connector or cable gland for cable entry.
3. In case of outdoor installation without using the water-proof connector or cable gland, please be aware of the protection against waterlogging.
4. Power Entry Standard : PF3/4"