

1 2 3 4 5 6

A

B

C

D

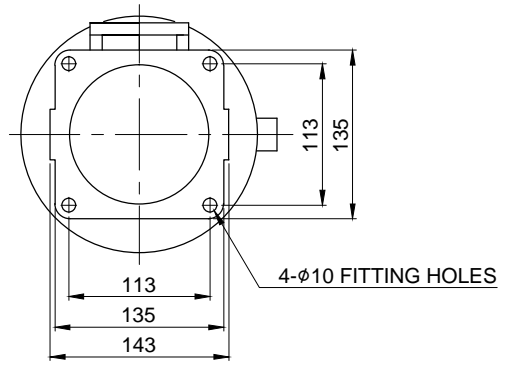
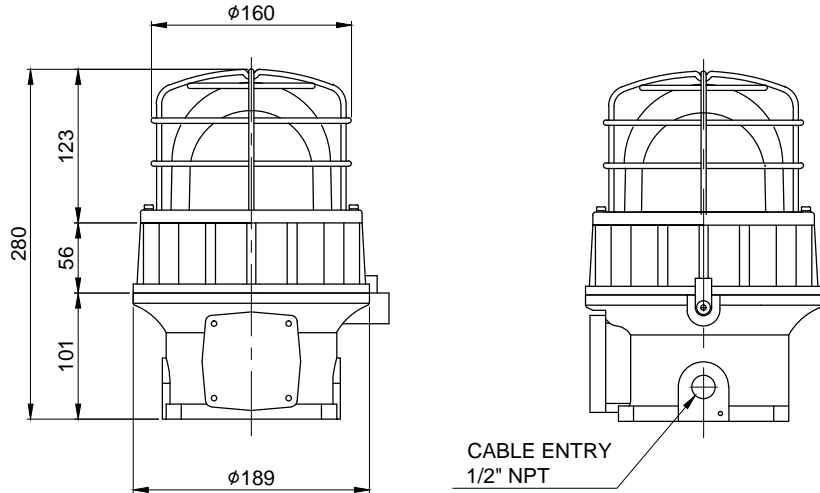

| MARK | DATE | REVISION | REVISER | APP .BY |
|------|------|----------|---------|---------|
| ①    |      |          |         |         |
| ②    |      |          |         |         |
| ③    |      |          |         |         |

|                  |     |                                     |        |             |
|------------------|-----|-------------------------------------|--------|-------------|
| MODEL NO         |     | SEL                                 |        |             |
| MATERIAL         |     | HOUSING-AL                          |        |             |
|                  |     | LENS-TEMPERED GLASS                 |        |             |
|                  |     | REFLECTOR-HEAT RESISTANT ABS        |        |             |
| COLOR OF LENS    |     | RED( ), AMBER( ), GREEN( ), BLUE( ) |        |             |
| FLASHING PER MIN |     | 60 - 80                             |        |             |
| USE VOLT.        | LED | CURRENT                             | DC12V  | MAX. 0.123A |
|                  |     |                                     | DC24V  | MAX. 0.094A |
|                  |     |                                     | AC110V | MAX. 0.035A |
|                  |     |                                     | AC220V | MAX. 0.017A |
| PROTECTION GRADE |     | WATER & DUST PROOF IP66             |        |             |
| CABLE ENTRY      |     | 1/2" NPT                            |        |             |
| COLOR OF HOUSING |     | MUNSELL NO. 7.5BG 7/2               |        |             |
| ACTION           |     | LED STEADY/FLASHING LIGHT           |        |             |

| FOR LINEAR DIMENSIONS  | ISO2768-1 : CLASS OF TOLERANCE |        |        |        |  | SURFACE FINISH |
|------------------------|--------------------------------|--------|--------|--------|--|----------------|
|                        | f                              | m      | Ⓢ      | v      |  |                |
| 0.5-3                  | ±0.05                          | ±0.1   | ±0.2   | -      |  |                |
| 3-6                    |                                |        | ±0.3   | ±0.5   |  |                |
| 6-30                   | ±0.1                           | ±0.2   | ±0.5   | ±1     |  |                |
| 30-120                 | ±0.15                          | ±0.3   | ±0.8   | ±1.5   |  |                |
| 120-400                | ±0.2                           | ±0.5   | ±1.2   | ±2.5   |  |                |
| 400-1000               | ±0.3                           | ±0.8   | ±2     | ±4     |  |                |
| FOR ANGULAR DIMENSIONS | 0-10                           | ±1°    | ±1°30' | ±3°    |  |                |
|                        | 10-50                          | ±0°30' | ±1°    | ±2°    |  |                |
|                        | 50-120                         | ±0°20' | ±0°30' | ±1°    |  |                |
|                        | 120-400                        | ±0°10' | ±0°13' | ±0°30' |  |                |

| Nr.                    | DWG. NO. | TITLE/ NAME | MAT'L    | QTY  | REFERENCE  |
|------------------------|----------|-------------|----------|------|------------|
| DSND BY                | CHKD BY  | CHKD BY     | APRV BY  | VIEW | DATE       |
| S.H.KIM                | J.H.PARK |             | J.K.HAN  | 3    | 2016.08.30 |
| TITLE                  |          |             | MODEL    |      |            |
| SEL<br>OUTLINE DRAWING |          |             | SEL      |      |            |
|                        |          |             | DWG. NO. |      |            |
|                        |          |             | SEL_OUT  |      |            |
| SCALE                  | SIZE     | REV         | SHEET    |      |            |
| N/S                    | A4       | 00          | 1/1      |      |            |

1 2 3 4 5 6

A4(297X210)