

1 2 3 4 5 6

A

B

C

D

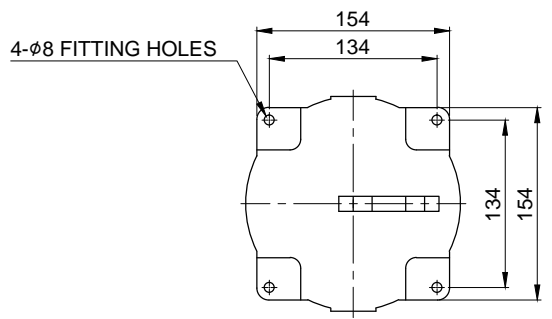
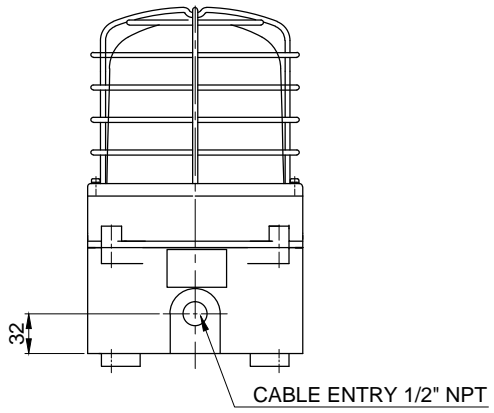
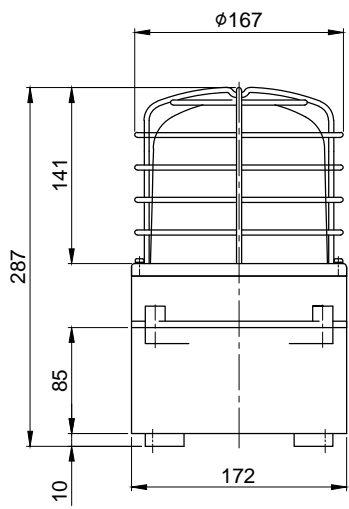

MARK	DATE	REVISION	REVISER	APP .BY
①				
②				
③				

MODEL NO		SEALR			
MATERIAL		HOUSING-AL			
		LENS-TEMPERED CLASS			
		REFLECTOR-PC			
COLOR OF LENS		RED(), AMBER(), GREEN(), BLUE()			
REV. PER MIN.		120 ~ 140			
USE VOLT.	LED	CURRENT	DC12V	1W	MAX. 0.183A
			DC24V		MAX. 0.127A
			AC110V		MAX. 0.035A
			AC220V		MAX. 0.017A
PROTECTION GRADE		WATER & DUST PROOF IP66			
CABLE ENTRY		1/2" NPT			
COLOR OF HOUSING		MUNSELL NO. 7.5BG 7/2			
ACTION		LED REVOLVING WARNING LIGHT			

	ISO2768-1 : CLASS OF TOLERANCE					SURFACE FINISH
	f	m	Ⓢ	v		
FOR LINEAR DIMENSIONS	0.5-3	±0.05	±0.1	±0.2	-	
	3-6			±0.3	±0.5	
	6-30	±0.1	±0.2	±0.5	±1	
	30-120	±0.15	±0.3	±0.8	±1.5	
	120-400	±0.2	±0.5	±1.2	±2.5	
	400-1000	±0.3	±0.8	±2	±4	
FOR ANGULAR DIMENSIONS	0-10	±1°		±1°30'	±3°	
	10-50	±0°30'		±1°	±2°	
	50-120	±0°20'		±0°30'	±1°	
	120-400	±0°10'		±0°13'	±0°30'	

Nr.	DWG. NO.	TITLE/ NAME		MAT'L	QTY	REFERENCE
DSND BY	CHKD BY	CHKD BY	APRV BY	VIEW	DATE	
S.H.KIM	J.H.PARK		J.K.HAN	3	2016.08.30	
TITLE			MODEL			
SEALR OUTLINE DRAWING			SEALR			
			DWG. NO.	SEALR_OUT		
SCALE	SIZE	REV	SHEET			
N/S	A4	00	1/1			

1 2 3 4 5 6 A4(297X210)