

1 2 3 4 5 6

A

A

B

B

C

C

D

D

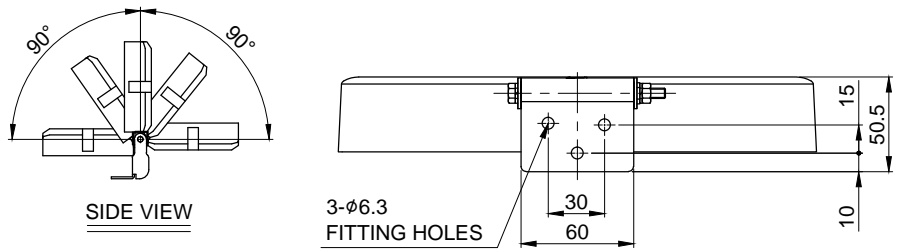
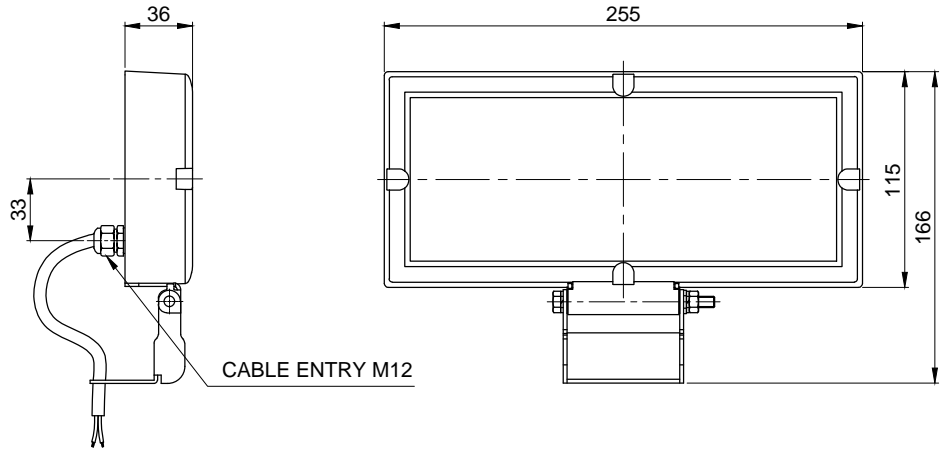

※ POWER CABLE : Dura & Flex-F VU(0.5sq X 2C) 450mm

MARK	DATE	REVISION	REVISER	APP .BY
①				
②				
③				

MODEL NO		QML-150-K			
MATERIAL		BODY-AL			
		LENS-CHEMICAL TEMPERED GLASS			
		COVER-AL			
		BRACKET-SUS430			
COLOR OF LENS		UNCLEAR			
USE VOLT.	LED	CURRENT	CHIP LED	DC24V	MAX. 1.250A
				AC110V	MAX. 0.215A
				AC220V	MAX. 0.104A
PROTECTION GRADE		WATER & DUST PROOF IP67 / IP69K			
CABLE ENTRY		M12			

FOR LINEAR DIMENSIONS	ISO2768-1 : CLASS OF TOLERANCE					SURFACE FINISH
	f	m	Ⓢ	v		
0.5-3	±0.05	±0.1	±0.2	-		
3-6			±0.3	±0.5		
6-30	±0.1	±0.2	±0.5	±1		
30-120	±0.15	±0.3	±0.8	±1.5		
120-400	±0.2	±0.5	±1.2	±2.5		
400-1000	±0.3	±0.8	±2	±4		
FOR ANGULAR DIMENSIONS	0-10	±1°	±1°30'	±3°		
	10-50	±0°30'	±1°	±2°		
	50-120	±0°20'	±0°30'	±1°		
	120-400	±0°10'	±0°13'	±0°30'		

Nr.	DWG. NO.	TITLE/ NAME		MAT'L	1	REFERENCE
DSND BY	CHKD BY	CHKD BY	APRV BY	VIEW	DATE	
S.H.KIM	J.H.PARK		J.K.HAN	3	2016.08.30	
TITLE			MODEL			
QML-250-K OUTLINE DRAWING			QML-250-K			
			DWG. NO.	QML-250-K_OUT		
SCALE	SIZE	REV	SHEET			
N/S	A4	00	1/1			

1 2 3 4 5 6

A4(297X210)