

1 2 3 4 5 6

A

A

B

B

C

C

D

D

MARK	DATE	REVISION	REVISER	APP .BY
①				
②				
③				

MODEL NO		QML-150-MF			
MATERIAL		BODY-AL			
		LENS-CHEMICAL TEMPERED GLASS			
		COVER-AL			
		BRACKET-AL			
COLOR OF LENS					
UNCLEAR					
USE VOLT.	LED	CURRENT	CHIP LED	DC24V	MAX. 0.580A
				AC110V	MAX. 0.110A
				AC220V	MAX. 0.054A
PROTECTION GRADE		WATER & DUST PROOF IP67 / IP69K			
CABLE ENTRY		M12			

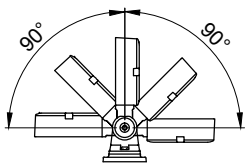
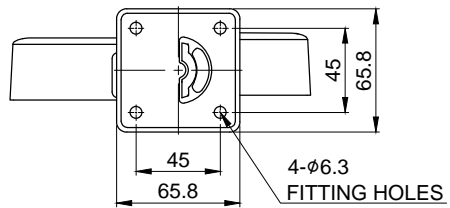
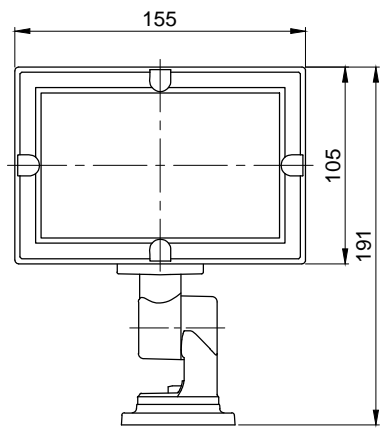
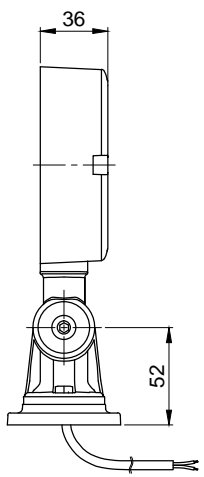

SIDE VIEW

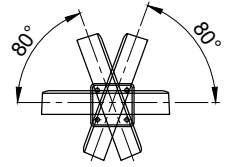

TOP VIEW

※ POWER CABLE : Dura & Flex-F VU(0.5sq X 2C) 450mm

ISO2768-1 : CLASS OF TOLERANCE					SURFACE FINISH	-		1		-	
FOR LINEAR DIMENSIONS		f	m	Ⓢ		v	Nr.	DWG. NO.	TITLE/ NAME	MAT'L	QTY
	0.5-3	±0.05	±0.1	±0.2	-	DSND BY	CHKD BY	CHKD BY	APRV BY	VIEW	DATE
	3-6			±0.3	±0.5	S.H.KIM	J.H.PARK		J.K.HAN	3	2016.08.30
	6-30	±0.1	±0.2	±0.5	±1	TITLE QML-150-MF OUTLINE DRAWING					
	30-120	±0.15	±0.3	±0.8	±1.5	MODEL QML-150-MF					
120-400	±0.2	±0.5	±1.2	±2.5	DWG. NO. QML-150-MF_OUT						
400-1000	±0.3	±0.8	±2	±4	SCALE N/S		SIZE A4	REV 00	SHEET 1/1		
FOR ANGULAR DIMENSIONS				Ⓢ	v						
	0-10	±1°		±1°30'	±3°						
	10-50	±0°30'		±1°	±2°						
	50-120	±0°20'		±0°30'	±1°						
120-400	±0°10'		±0°13'	±0°30'							

1 2 3 4 5 6

A4(297X210)